

# S10 Pro Datasheet

## Product Overview

The S10 Pro is the most efficient direct drive valve for high-flow applications, delivering up to 250 l/min while maintaining pressure and reliable operation under continuous duty cycles.

Compact and lightweight, it replaces bulky traditional servo proportional valves while sustaining bandwidth and reliability under demanding conditions. Perfect for presses, power generation and large-scale test systems, it enables more throughput with less energy and less weight.

### Key Features

- Onboard electronics with spool position feedback
- Rated flow of up to 250 l/min (at 70 Bar  $\Delta P$ )
- Based on the NG10 port pattern
- Bandwidth > 150 Hz (-3 dB, up to  $\pm 25\%$  FS)
- Chip shear capability of > 700 N
- Valve mass of 4.2 kg

### Customisation

The S10 Pro is designed to be customised. Standard modifications include:

- Rated flow rates of up to 250 l/min
- Multiple voltage or current control options
- Various seal materials available
- Non-standard configurations available

## Contents

Technical Data.....	2
Performance Graphs .....	3
Standards References .....	4
Unit Dimensions .....	4
Mounting Dimensions .....	5
LED Status .....	5
SKU Selection .....	6

## Contact Us

If you have any questions about using the S10 Pro, or if you need a non-standard configuration, we would be happy to hear from you.

Contact us using the details below and one of our team will be there to assist you.

33 Colston Avenue, Bristol, BS1 4UA  
+44 (0)333 090 5140  
sales@domin.com  
[domin.com](http://domin.com)



# Technical Data

## General Data

Design	Direct Drive Servo Valve	
Actuation	Rotary-Linear NG10 ISO	
Size	NG10	
Mounting Interface	ISO 4401-05-04	
Ambient Temperature	°C (°F)	-20 to +60 (-4 to +140)
Mass	kg (lb)	4 (8.8)
Vibration Resistance <sup>(1)</sup>	g	30
Shock Resistance <sup>(2)</sup>	g	50

## Hydraulic Data

Max. Operating Pressure (P, A, B)	Bar (psi)	350 (5,000)	
Max. Operating Pressure (T)	Bar (psi)	250 (3,600)	
Fluid	Hydraulic Oil DIN 51524		
Fluid Temperature	°C (°F)	-20 to +80 (-5 to +175)	
Filtration	ISO 4406 (1999) 18/16/13		
Viscosity	cSt	5 to 500	
Rated Flow <sup>(3)</sup>	l/min (gpm)	50 to 170 (13 to 45)	170 to 250 (45 to 66)
Flow Maximum	l/min(gpm)	321 (85)	475 (125)
Pressure Gain	%/%	>40	
Leakage at 100 bar	l/min (gpm)	< 1 (0.4)	<3 (0.8)

## Static/Dynamic Data

Response Time at 100% <sup>(4)</sup>	ms	< 7	
Frequency Response (-3dB gain, ±25% signal) <sup>(4)</sup>	Hz	> 120	> 100
Frequency Response (-90deg phase, ±25% signal) <sup>(4)</sup>	Hz	> 140	> 130
Hysteresis	%	< 0.2	
Threshold	%	< 0.1	
Null Shift	%	< 1	

1. BS EN 60068-2 (20-35 Hz, 16 g for 15 minutes per axis, 35-2000 Hz, 35 g for 15 minutes per axis).

2. BS EN 60068-2 (20 shocks 50 g in Z axis).

3. Rated at a ΔP of 70 bar (35 bar per edge), 250 l/min only available for Axis cut valves.

4. Measured as 90% output rise time with Δ70 bar P-T (two control edges).

# Performance Graphs

Step Response<sup>(1)</sup>

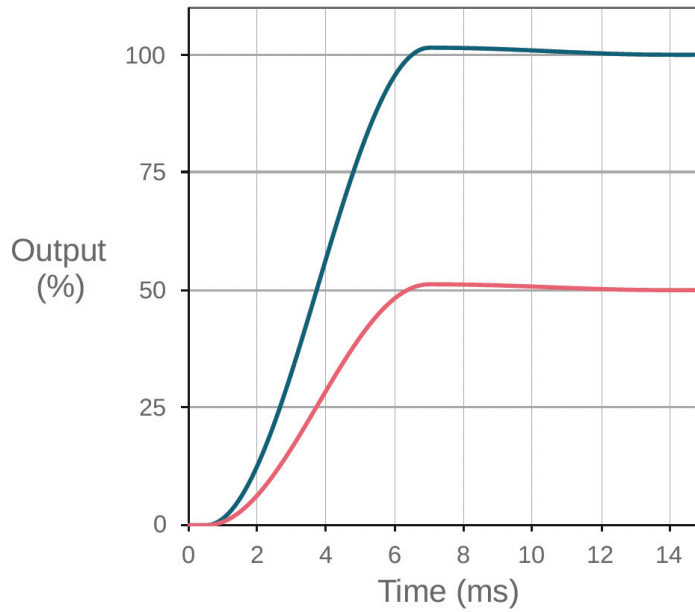

Frequency Response<sup>(1)</sup>

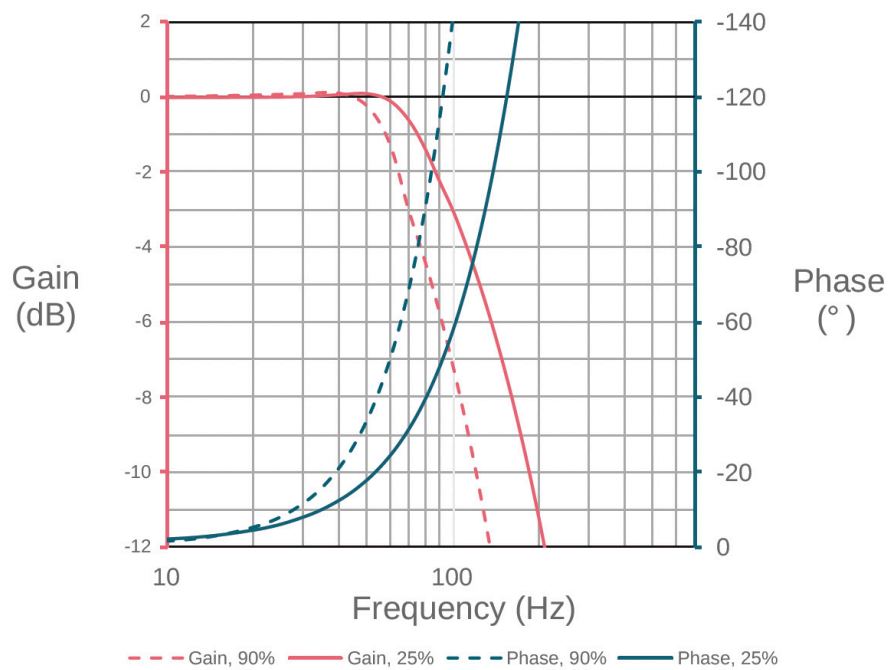

1. Measured at a 70 bar pressure drop.

# Standards References

EMC Regulations:	Immunity: EN 61000-6-2, Emission: EN 61000-6-3
Performance Tests:	ISO 10770-1
Pressure Rating:	ISO 10771
Hydraulic Interface:	ISO 4401-05-04

# Unit Dimensions

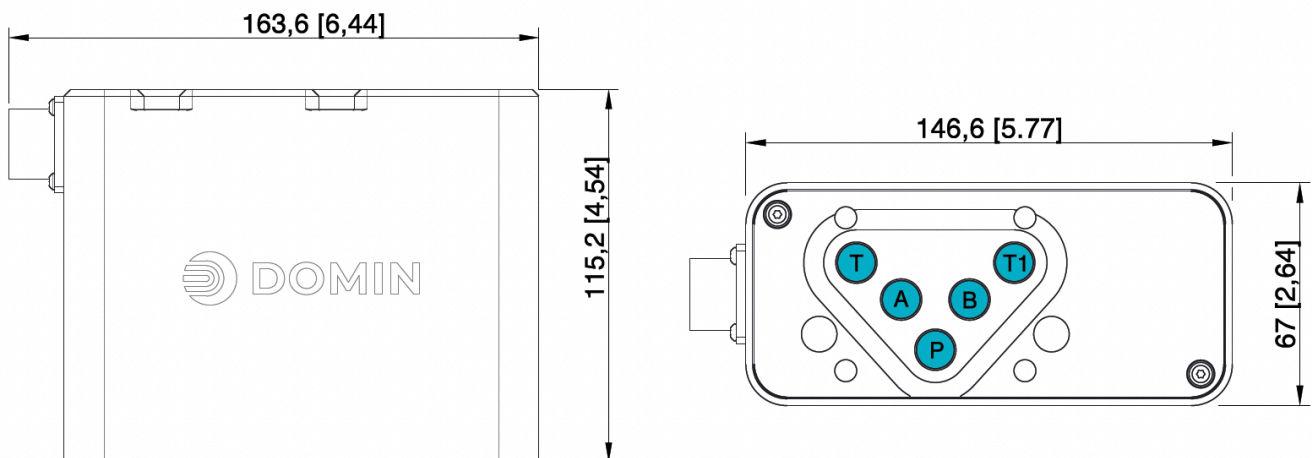

Nominal dimensions are displayed in mm, [] indicates inches. Not to scale.

# Mounting Dimensions

		P	A	B	T	T	X <sup>(1)</sup>	Y <sup>(1)</sup>	F1	F2	F3	F4
Diameter	mm	11.2	11.2	11.2	11.2	11.2	6.3	6.3	M6	M6	M6	M6
X Position	mm	27	16.7	37.3	3.2	50.8	-8.0	62	0	54	54	0
Y Position	mm	6.3	21.4	21.4	32.5	32.5	11	11	0	0	46	46

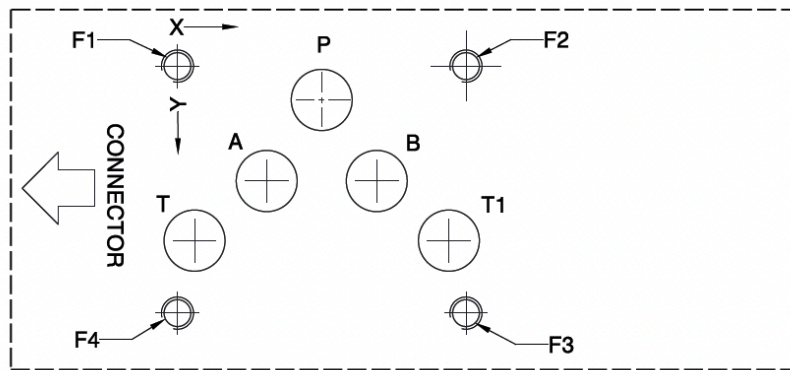

## Bolts (F1, F2, F3, F4)

Type: M6 x 120 DIN EN ISO 4762-10.9  
 Required Torque: 13 Nm

## O-Rings (P, A, B, T, T1, X<sup>(1)</sup>, Y<sup>(1)</sup>)

Type: 5x ISO 3601-1-014  
 Type: <sup>(1)</sup> 2x ISO 3601-1-011

1. Valve includes seal grooves for X and Y ports for installation in existing systems – X and Y connections are NOT required for valve operation. Port X & Y not in use, seals are for blanking only.

# LED Status

LED Colour	LED State	Motor Drive State	Valve State
Green	Solid - On	Motor Drive On	Valve OK
	Flashing	Motor Drive On	Warning Present
Red	Solid - On	Motor Drive Off	Valve OK
	Flashing	Motor Drive Off	Error Present

# SKU Selection

Use our SKU builder to configure your Domin Valve. If you need a non-standard setup or a bespoke option, just get in touch – we can tailor a solution to suit your exact requirements.

S10 Pro		1	2	3	4	5	6	7	8	Custom ID
<b>Code 1</b>	<b>Rated Flow</b>									<b>Code 9</b>
50 to 250	l/min									
50 to 250R	l/min, Reverse									
<b>Code 2</b>	<b>Spool Lap Condition</b>									<b>Code 8</b>
A	Axis Cut									N
D	Deadband									V
O	Overlap									X
X	Special Enquiries									
<b>Code 3</b>	<b>Input/output Signal</b>									<b>Code 7</b>
A	± 10 V									R
B	± 20 mA									X
C	4 to 20 mA									
D	± 5 V									<b>Code 6</b>
E	± 5 mA									N
F	± 10 mA									Y
G	± 50 mA									
H	± 40 mA									<b>Code 5</b>
I	± 25 mA									E
X	Special Enquiries									E4
<b>Code 4</b>	<b>Power off Position</b>									X
C	Centre									
X	Special Enquiries									

## Code 1 Rated Flow

Any value in range 50 to 250 LPM rated at 35 bar  $\Delta P$  per control edge. R – Suffix for reversal of A and B port e.g. 250R

## Code 2 Lap Condition

	Overlap Region (%)	Flow Gradient (%/%)	
A Axis Cut	0	100	1% mechanical overlap, linearised
D Deadband	$\pm 10$	0	10% overlap with flow dead band
O Overlap	$\pm 3$	50	3% overlap linearised to 50% gain over centre
X	For other options please enquire		

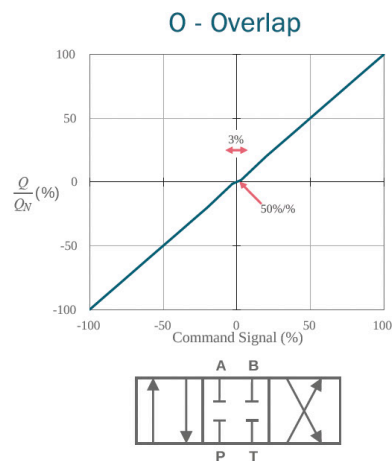
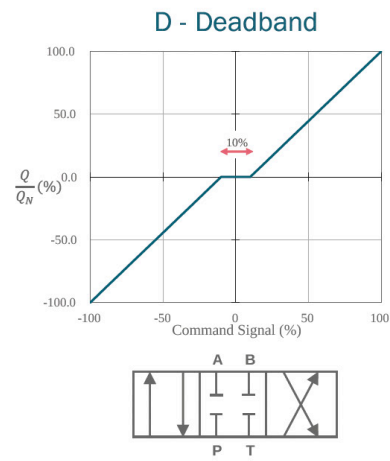
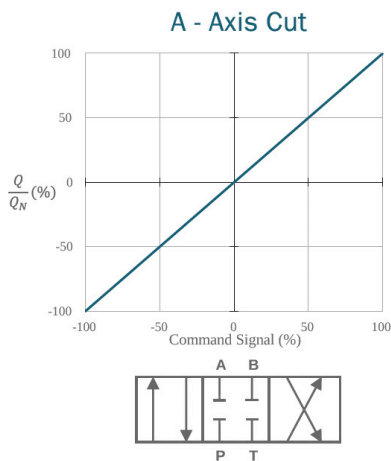

## Code 3 Control Methods

Code	Input Signal	Input Impedance	Output Signal	Output Load Impedance
A	$\pm 10$ V	200 k $\Omega$	$\pm 10.5$ V	-
D	$\pm 5$ V		$\pm 5.25$ V	-
E	$\pm 5$ mA	200 $\Omega$	$\pm 5.25$ mA	600 $\Omega$
F	$\pm 10$ mA		$\pm 10.5$ mA	
B	$\pm 20$ mA		$\pm 21$ mA	
I <sup>(2)</sup>	$\pm 25$ mA	402 $\Omega$	-	-
C <sup>(1)</sup>	4 to 20 mA		3.8 to 21 mA	600 $\Omega$
G <sup>(2)</sup>	$\pm 50$ mA	402 $\Omega$	-	-
H <sup>(2)</sup>	$\pm 40$ mA		-	-
X	For other options please enquire			

1. For 4 to 20 mA input signal, a current input below 2 mA will disable the motor drive
2. Configuration available for Input only. Default output will be Control Mode - A
3. Valves with a current command signal use a 0.1% tolerance shunt resistor to measure demand current.
4. For differing input and output signals, use two letters, e.g. AC denotes  $\pm 10$  V Input and 4 to 20 mA output

## Electrical

Supply Voltage (Operational)	V	22 to 30
Supply Voltage (Absolute) <sup>(1)</sup>	V	-0.5 to 33
Current Consumption <sup>(2)</sup>	A	0.8
Peak Current Draw <sup>(3)</sup>	A	8

1. Conditions outside the absolute maximum ratings may cause permanent damage to the valve. These are absolute ratings only. Operation of the product outside of the nominal operating conditions is not guaranteed and may affect product reliability
2. Approximate current consumption for 100 Hz at 25 % amplitude
3. The valve supply must be protected with a 10 AT fuse or equivalent overcurrent protection device

## Code 4 Power Off Position

C	Centre. The spool is intended to return to centre passively under typical flow conditions.
X	For other options please enquire

## Code 5 Electrical Connectors

### 6 + PE Circular Connector (E)

Type: Case-Mounted

Termination: Connector according to EN 175201-804/MIL 5015 equivalent, shell size 14

Number of Contacts: 7

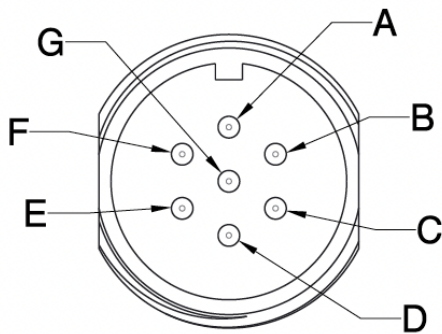

Pin	Function	Description
A	Supply +	+24 V
B	Supply 0 V	0 V
C <sup>(1)</sup>	Output - Enable input	Output 0 V Reference Drive enable input
D	Input +	Differential input signal, +
E	Input -	Differential input signal, -
F	Output +	Output Signal
G	Earth	-

1. When the enable function is selected, the function of pin C is the enable input. This replaces the standard pin function.

### 4 Pin Circular Connector (E4)

Type: Case-Mounted

Termination: Connector according to EN 175201-804/MIL 5015 equivalent, shell size 14

Number of Contacts: 4

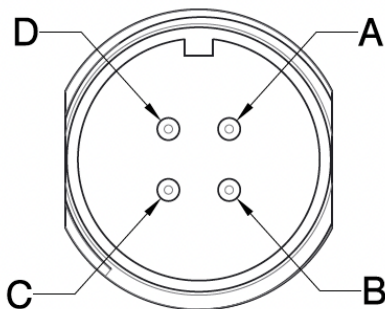

Pin	Function	Description
A	Supply +	+24 V
B	Input +	Differential input signal, +
C	Input -	Differential input signal, -
D	Supply 0 V	0 V

## Code 6 Enable Modes

Valves can be provided with an enable function. This allows the valve to be enabled or disabled by varying the voltage into the enable pin. Note that valves with a code C command type can also be enabled or disabled using the command signal; see the corresponding table above for further details. Enable function is only applicable with Code E electrical connector option.

N No Enable Functionality

Y Enable mode on

Normal Operating Conditions		Units	Min.	Typical	Max.
Enable Mode	Drive On	V	9	-	30
	Drive Off	V	0	-	5
	Input Impedance	kΩ	-	15	-

## Code 7 Fluid Types

R Recommended - any hydraulic oil in accordance with DIN 51524, filtered in accordance with ISO4406 18/16/13. Compatibility with water-free synthetic fluids available on enquiry.

X For other options please enquire

## Code 8 Seal Materials

N Nitrile (Shore 90)

V Viton (Shore 85)

X For other options please enquire